

**P
11** **SDCV
SOLENOID
VALVE**

TYPE: 23 Series
MWP: 1600kPa

The 23 series is a cost effective, reliable product designed specifically for applications in the building services, fire services, mining and irrigation markets. The reinforced diaphragm is designed to operate across the complete pressure range of the valve, providing leak tight shut off and stable control.

The Body and Cover are manufactured from FBE coated Ductile iron for added strength, reduced weight and corrosion protection.

Applications:

A normally closed pilot solenoid is used to open the main valve when power is applied.

By using an electrical signal to open or close the main valve this produces a very cost effective actuated valve that can be integrated into any system using electronic control or switching.

Remote operation, level control, wash down or fire service are typical applications.



Sizing and Performance

Maximum operation pressure 1600kPa
Minimum differential pressure 35 kPa
Maximum operating temperature 70c

ACTIVFIRE Approvals

Mack series 23 valves have been assessed by the CSIRO as conforming to the relevant sections of Australian Standards: 4118.1.5-1996 & 4118.1.8-1999

Single Diaphragm Control Valves

23	#	##	###
Base No.	- Body Material	- Pilot Configuration	- Size
23	6 Ductile Iron	26 Solenoid	050
23	6 Ductile Iron	26 Solenoid	080
23	6 Ductile Iron	26 Solenoid	100
23	6 Ductile Iron	26 Solenoid	150

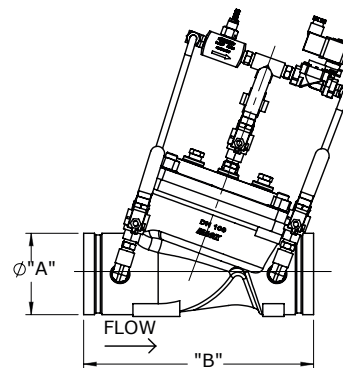
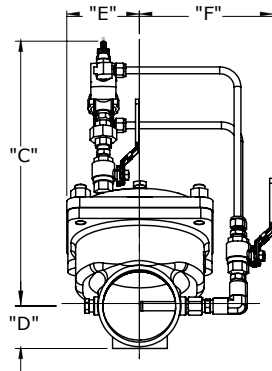

Dimensions										Volume of cover chamber (L)	Weight (Kg)	
A Inlet OD	B Length	C C/Line To Top	D C/Line To Bottom	E Width	F Width	Flow Range (L/sec)	LPS/√kPa	USGPM/√psi	m3/Hr/√M			
50mm	60.3	205	305	35	65	170	0.7-14.5	1.45	60.6	4.5	0.16	7
80mm	88.9	250	330	50	85	175	1.5-28.0	2.95	122.9	9.2	0.38	13
100mm	114.3	320	365	60	105	190	1.8-50.0	5.10	214.5	15.8	0.73	20.5
150mm	165.1	415	420	85	145	225	2.5-112.0	11.50	476.0	35.6	2.00	48

SDCV SOLENIOD VALVE

**P
12**

TYPE:23 Series
MWP: 1600 kPa

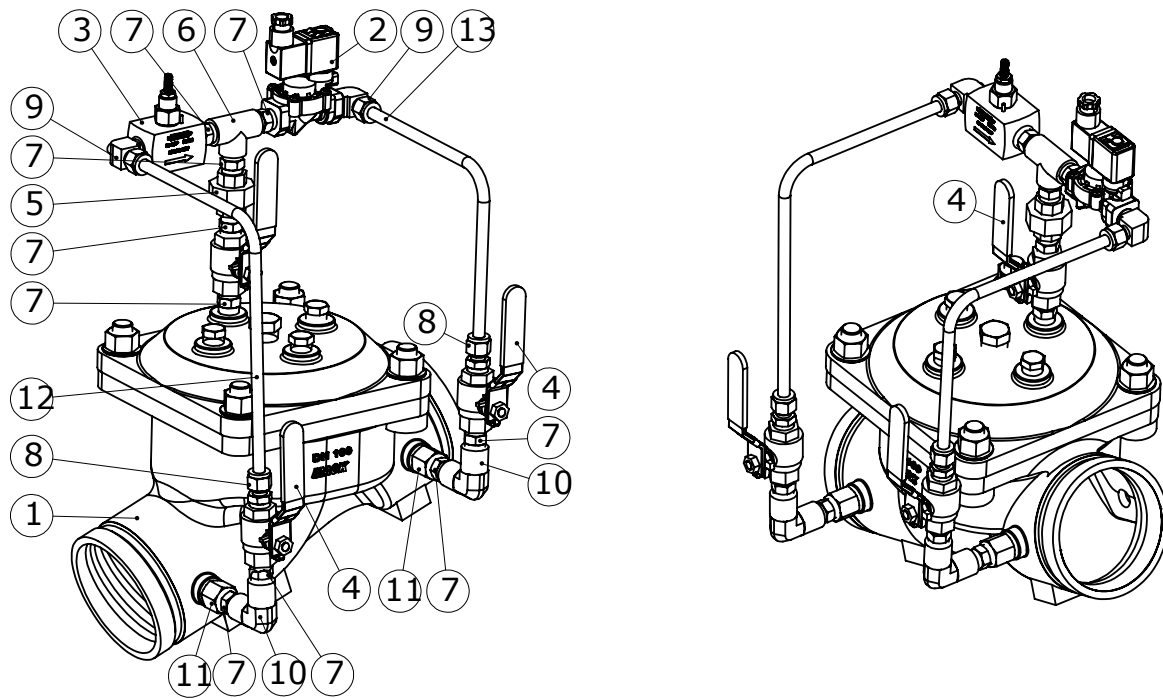

Item No.	Part Number	Description	Material	Qty
01	23-6-XXX	SDCV MAIN VALVE ASSY.	Refer BOM	01
02	432-1-010	RAMCO RCD21	Refer BOM	01
03	428-2-010	NEEDLE VALVE	Refer BOM	01
04	5098-010	BALL VALVE BSPT	SS/PTFE	03
05	9202-C03-034	BARREL UNION 3/8" BSPP FEMALE x FEMALE	A.B.BRASS	01
06	9224-C03-034	ALL FEMALE TEE, 3/8" BSPT	A.B.BRASS	01
07	9215-C03-034	HEX NIPPLE 3/8 BSPT MALE	A.B.BRASS	09
08	9206-C03-034	STRAIGHT CONNECTOR 3/8" BSPT X 3/8" TUBE	A.B.BRASS	02
09	9213-C03-034	ELBOW CONNECTOR 3/8" BSPT X 3/8" TUBE	A.B.BRASS	02
10	9209-C03-034	ELBOW 3/8" BSPT FEMALE - FEMALE	A.B.BRASS	02
11	7116-001-360	BUSH	S.S. A479	01
12	7105-027-021	INLET TUBE TO BE TRIMMED	S.S.	01
13	7105-027-021	OUTLET TUBE TO BE TRIMMED	S.S.	01