

33 SERIES

AUTOMATIC CONTROL VALVE (ACV)



- > **FOR:** Fluids non-injurious to construction
- > **WORKING PRESSURE:** 35 - 3500 kPa
- > **INDUSTRY:** Municipal, Mining & Infrastructure

The 33 Series range of Automatic Control Valves (ACV) has been optimised to represent a major step forward in control valve application.

The 33 Series ACV continues to represent the high quality, reliable and dependable valve that Mack has always stood for, and it has now been re-engineered for today's demanding expectations.

All of our ACVs come standard with full 316 stainless steel trim for enhanced corrosion protection (unless ordered for bespoke application) and are designed and manufactured in accordance with AS5081. Mack's 33 Series is used across Water Management, Mining and Infrastructure where the demand for absolute dependability exists. It can be fitted for in excess of 20 configurations to ensure it does the job you need.

Selection & Application

The new 33 Series range comes standard in ductile iron, FBE coated, and is available in sizes from 50mm to 300mm.

This ACV can be used for a whole range of liquid mediums including potable water, seawater, aviation fuel, diesel and many others. It has been certified to AS4020 for products in contact with drinking water. Specialist application pilot systems allow the valve to be used in all applications from water level management to pump and flow control.

PRODUCT NUMBERING Automatic Control Valves												
33	-	#	#	#	-	##	-	###				
Base No.	-	Body Material		Trim Material		Special Feature		-	Pilot Configuration	-	Size	
33	-	6	Ductile Iron	2	BR	S	Standard	-	11	Rate of Flow	-	050
				4	SS	C	Anti-Cavitation Trim	-	13	Sustaining/Relief	-	080
						V	V-Port Trim	-	18	Pressure Reducing	-	100
						F	Viton Elastomers	-	22	Main Valve Only	-	150
						I	Visual Position Ind.	-	23	Ball Float	-	200
								-	26	Solenoid	-	250
								-	28	Altitude	-	300
								-	34	Twin Solenoid		



Re-engineered for today's demanding expectations.

ITEM NO.	DESCRIPTION
1	Body
2	Cover
3	Seat
4	Cover Bearing
5	Spring
6	Stem
7	Diaphragm Washer
8	Disc Retainer
9	Disc Guide
10	Diaphragm
11	Disc
12	Spacer Washer
13	Hex Nut
14	Hex Plug
15	Hex Plug
16	Stud
17	Washer
18	Hex Nut
19	Eye Bolt

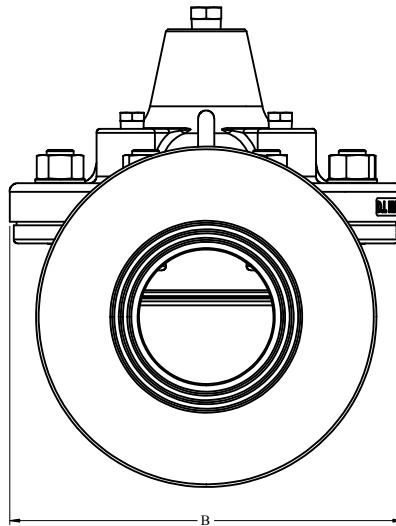

All build options are available from Mack on special order, thus enabling clients to create their own specifications for their own specific needs, but our stock is based around common material specifications favoured by the water, mining and infrastructure industries.

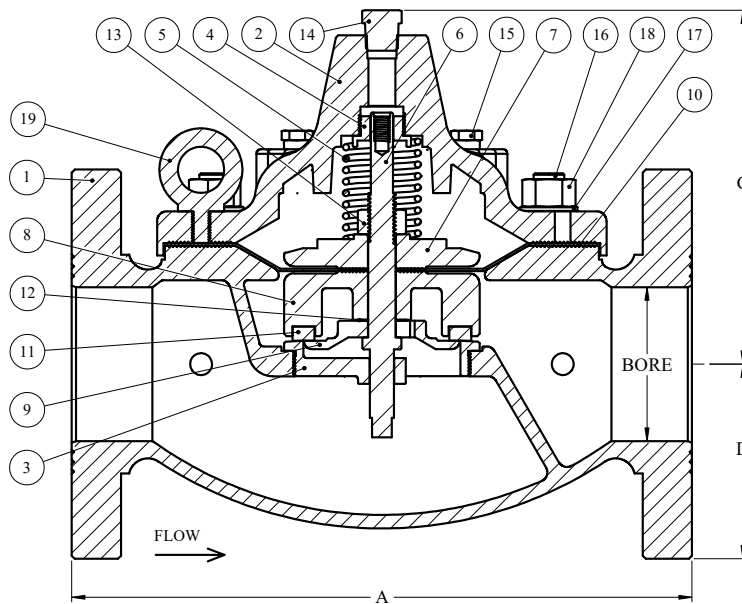

	Dimensions				Standard Port			V-Port			Anti-Cavitation Trim			Volume of Cover Chamber (L)	Weight (Kg)
	A	B	C	D	Flow Range (L/sec)	Head Loss Required (kPa)	Cv Factor	Flow Range (L/sec)	Head Loss Required (kPa)	Cv Factor	Flow Range (L/sec)	Head Loss Required (kPa)	Cv Factor		
50mm	245	168	141	83	1.5 - 14	69	1.65	0.7 - 14	108	1.32	0.25 - 14	191	0.99	0.12	17
80mm	349	230	183	105	3.0 - 30	87	3.23	1.5 - 30	135	2.59	0.5 - 30	240	1.94	0.38	35
100mm	403	292	230	127	5.0 - 52	98	5.24	2.5 - 52	153	4.19	0.8 - 52	272	3.14	0.60	63
150mm	533	405	208	159	11 - 118	92	12.28	6.0 - 118	144	9.82	2.0 - 118	255	7.37	2.00	136
200mm	671	507	380	190	20 - 204	120	18.56	10 - 204	188	14.85	3.0 - 204	334	11.14	4.20	216
250mm	791	604	451	222	30 - 321	131	28.08	16 - 321	204	22.47	5.0 - 321	363	16.85	7.60	345
300mm	914	706	551	285	45 - 460	115	42.93	25 - 460	180	34.35	7 - 460	320	25.75	12.0	579

NOTES: 1) Maximum flow is based on velocity of 6 m/s. 2) Recommended maximum velocity for continuous service is 6 m/s. 3) Recommended maximum velocity for intermittent service is 7.5 m/s. 4) Recommended maximum velocity for momentary service is 14.0 m/s. 5) Cv units are L/sec per $\sqrt{\text{kPa}}$. 5) All specific sizing can be calculated as per application

