



Quality and Assurance

Our Automatic Control Valves are manufactured to strict control standards, are covered by our Mack Valves Quality Guarantee and have achieved the highest industry certifications.

AS5081

Hydraulically operated control valves for waterworks purposes are covered under Australian Standard AS5081. This covers the design, performance and material construction. We are 3rd party certified as compliant with this standard.

AS4020

Compliance with AS4020 ensures our valves have passed the most rigorous testing and that water condition is of the utmost quality. Tests evaluate the quality of the water-based on acceptable limits of micro-organism growth, metallic and non-metallic elements levels, visual

appearance and taste. Compliance with AS4020 also guarantees that our valves are compliant with the requirements for drinking water.

WaterMark

WaterMark certification is mandatory and provides assurance plumbing and drainage products work properly, and that water is fit for consumption. Mack's Automatic Control Valves proudly display the WaterMark certification logo and provide peace of mind for all plumbing or drainage installations where quality, reliability and performance can't be compromised.

Ensure reliability in critical environments and essential services. Choose a Mack quality product you can trust.

Learn more about our extensive range of Water Management products at mackvalves.com

To speak directly to our specialist sales team to discuss your Water Management valve needs, or to get a personalised quote, call **+61 3 9737 5200**



YOUR MACK QUALITY GUARANTEE

Mack Valves Pty Ltd is committed to providing Australian and world markets with a range of industrial valves manufactured to the highest quality and in conformity with appropriate international standards. The Company will maintain its position as a recognised leader in valve design and manufacturing techniques at all times seeking to employ the world's best practice. The requirements and recommendations of ISO 9001:2015 have been adopted without exclusions as the basis for the Company's Quality Management System.

Proud member of the HEROSE Group



Automatic Control Valves

Directing the flow

Trusted valves to manage our most precious resource

Automatic Control Valves (ACV)

Water Distribution + Mining Industries + Infrastructure

For more than eighty years, Mack Valves has been manufacturing Automatic Control Valves following our strict quality control standards. Our tried and tested designs ensure reliability in critical environments and all have our Mack Quality Guarantee.

Products can be supplied in all sizes and materials to suit various applications and pressures including: cast iron, ductile iron, stainless steel, bronze, nickel aluminium bronze and more.

Specialised application pilot systems are available in straight through, angle seat, right angle, double chamber and double diaphragm configuration.

We also offer bespoke solutions, so please get in touch to see how we can help you.



Renowned for their superior design, Mack's Automatic Control Valves offer efficient and trouble free reliable operation.

- Hydraulically operated single seat diaphragm actuated globe valves
- Have a resilient seat fully retained by a disc retainer to ensure drip tight seal
- Packless design for long life and maintenance free operation
- Can be serviced in-line
- Only one moving part
- Diaphragm is not used as seating surface
- Controlling the rate at which pressure is applied and released to the top chamber allows the valve to modulate control at any position between fully open and fully closed
- Different pilot systems change the way in which the control of the diaphragm chamber is achieved
- Fully guided design

FEATURES

- Use with a multitude of liquid mediums including: potable water, seawater, aviation fuel, diesel and many others
- Flanged connections to international standards
- Internal and external epoxy coating, fusion bonding and alternative coating materials on request



VALVE CONFIGURATIONS

- Pressure reducing
- Pressure relief
- Level control
- Solenoid operations
- Rate of flow control
- Check
- Altitude
- Pump control
- Deluge
- Electronic control
- Surge anticipation

TRIM DESIGNS

- Standard flat disc
- Anti-cavitation trim for severe service
- Various combinations of pilot and hydraulic systems for multi-functional operation, eliminating the need for multiple valves to be installed

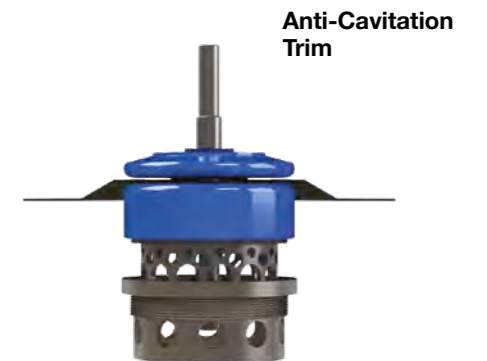

Automatic Control Valves for Water Distribution

Mack Automatic Control Valves (ACVs) are used extensively in water distribution systems for maintaining water levels, pressures, flow rates and protection of pipe work and equipment. High water pressure reduces the life of water supply assets and also causes unnecessary water loss due to leakage and excessive consumption.

> PRESSURE REDUCING

Keep downstream pressure constant with a pilot control valve. Sensing the downstream pressure, it activates the ACV to allow flow when the downstream pressure is lower than the spring pressure, setting on the pilot valve.

> PRESSURE REDUCING & CHECK

Prevent back-flow when the downstream pressure exceeds the upstream pressure. The valve closes slowly to prevent water hammer and to protect the system from damage.

> PRESSURE SUSTAINING & PRESSURE RELIEF

Eliminate problems with sustaining back pressure, pressure relief and uploading functions in bypass systems. Its rapid opening capability helps to maintain steady line pressure, while its slow closing prevent surges and makes it easy to set a maximum flow rate.

> PRESSURE SUSTAINING & CHECK

Maintain constant upstream pressure to close system tolerances by relieving the excess pressure downstream. The valve closes and positively prevents

return flow, over-pumping and pump cavitation caused by excessive downstream demands.

> RATE OF FLOW

Maintain maximum allowable flow rate to prevent the lowering of supply pressure and limit the primary water supply to a pre-set flow, which is actuated by differential pressure.

> ALTITUDE

Control high water level in reservoirs. The non-throttling valve allows the reservoir to fill and close when it reaches its setpoint at top water level. Add on features include back pressure sustaining, rate of flow, solenoid shut-off, pressure reducing, closing/opening speed control, position indicator and delayed opening.

> FLOAT LEVEL CONTROL

On/Off Float Valves are non-modulating valves that accurately control the liquid level in tanks. These valves are designed to open fully when the liquid level falls and close drip-tight at top water level. Valves can be supplied with a simple cistern cock pilot or a bi-level control that allows adjustment of the opening-closing level.

> MODULATING FLOAT CONTROL

Equalise variations in supply and demand to maintain a constant level in a reservoir. Can be balanced to either the in-flow or the out-flow rates. Minimum pressure can be sustained due to the addition of a pressure sustaining pilot valve.

> PUMP CONTROL

Prevent reverse flow regardless of the solenoid or diaphragm assembly position using the line pressure for its operation. The pump starts against a closed valve and regulates both the opening and closing rates which can be adjusted and controlled separately.

> PUMP CONTROL AND CHECK VALVE

Control surges in a pipeline on the discharge side of a booster pump. By starting and stopping against a closed valve, it's possible to prevent reverse flow, regardless of solenoid or diaphragm assembly position and to regulate both the opening and closing rates to protect the system.

> DUAL STAGE PRESSURE REDUCING

Get automatic control dual pressure with the application of a pilot system with two independent reducing pilots, with a calibrated orifice plate or a 3-way solenoid. As the flow increases, so does

the flow across the orifice plate until it reaches the set point of the second pilot, causing the valve to switch over and control at higher pressure.

> SOLENOID ON/OFF

Mack solenoid-controlled, automatic control valves are available with a range of three-way or two-way solenoid pilot valves of various voltages, and open or closed when energised.

> TWIN SOLENOID OPERATION

Supplied with a pilot system having two normally closed solenoid valves linked to a PLC controller or SCADA system. Each solenoid is energized independently for varying application. When used in conjunction with a PLC, complex routines regarding pressure reduction/sustaining, flow compensation and level control can be written. The valve can be fitted with a hydraulic backup so that the valve returns to hydraulic control during power failure.

> ELECTRONIC PILOT CONTROL

Change the set point as the flow in the system changes with a reducing pilot to an electronic motor that receives signals from a PLC or SCADA. In case of power failure, the valve continues to control the pressure to the last known set point. Motors with a manual override to change the set point without power and fail to pre-set point are available.

Guarantee your water supply. Reduce leakage and excessive consumption.



High Capacity Solenoid Valve

Our valves are renowned for their superior design, efficient operation and dependability in the harshest of environments.

Automatic Control Valves for the Mining Industry

Automatic Control Valves can be used successfully in the mining industry utilising product configurations from our Water Distribution range, including Level Control Float, Altitude and Pressure Relief valves.

> DUST SUPPRESSION

Dampen dust and prevent wind-blown dust contamination, fire, or dust explosion with the use of Solenoid or Air Pilot configurations in the dust suppression sprinkler system.

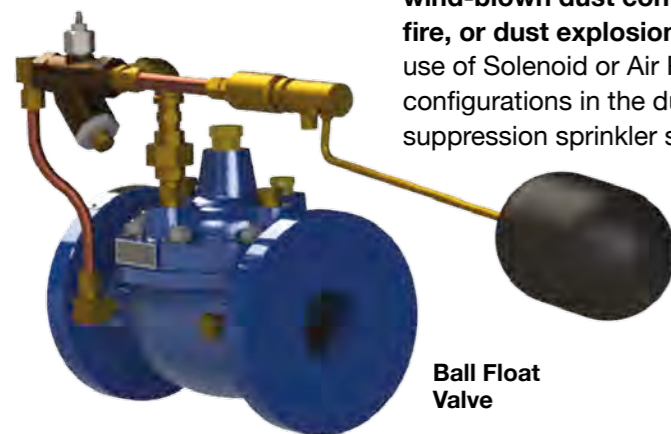

Ball Float Valve

> DEWATERING

ACVs can be supplied in various configurations to assist in mine dewatering applications.

> PRESSURE REDUCING

Reduce the head pressure below ground from the pump outlet, to a maintained fixed set point.

> FIRE PROTECTION

Varying configurations can be used to achieve a purpose built fire control system for plant and asset protection.

Automatic Control Valves for Infrastructure

Mack Valves supplies ACVs that are listed and comply with Australian Scientific Services Laboratory (SSL) specifications for use in the Infrastructure Industry.

> DELUGE

Deluge Valves are used in high hazard fire zones to provide suppressant to sprinkler zones when a fire is sensed. They are available in either air-operated or solenoid operated. A pressure reducing function can be added to provide a specific flow at each sprinkler head within the zone. Available in Angle Seated configuration which provides superior flow characteristics reducing head loss and allowing selection of smaller valves. Used for deluge fire protection systems in tunnels and large hazardous areas.

> PRESSURE REDUCING

Maintain an accurate downstream pressure in high-rise multi storey buildings to ensure correct pressures in combined mains at safe working limits.

> PRESSURE RELIEF

Respond to upstream pressure and slow closing to minimise water hammer used on pump sets to maintain pressure irrespective of system demand by bypassing excess water. Diaphragm operated to comply with AS2945.

> FLOAT VALVES

Maintain water level in fire tanks to ensure water is available to the system at all times during a fire.

Includes:

- drip-tight positive seal
- removable seat insert
- diaphragm assembly guided top and bottom
- in-line servicing.

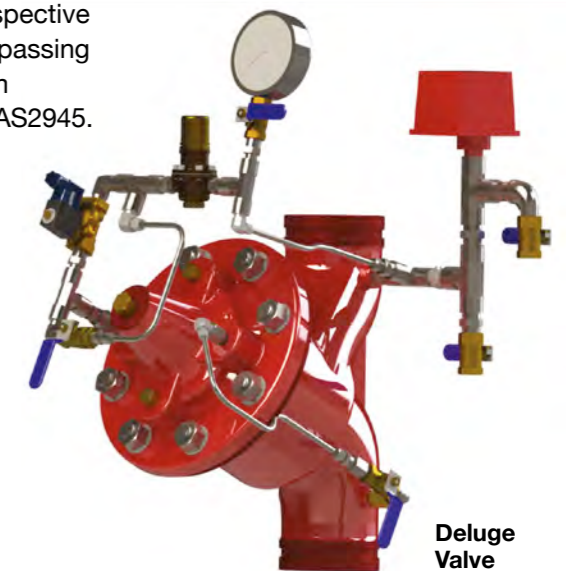

Deluge Valve

We engineer real world solutions to keep the energy flowing across our cities and industries.



33 SERIES

AUTOMATIC CONTROL VALVE (ACV)

- > FOR: Fluids non-injurious to construction
- > WORKING PRESSURE: 35 - 3500 kPa
- > INDUSTRY: Municipal, Mining & Infrastructure



The 33 Series range of Automatic Control Valves (ACV) has been optimised to represent a major step forward in control valve application.

The 33 Series ACV continues to represent the high quality, reliable and dependable valve that Mack has always stood for, and it has now been re-engineered for today's demanding expectations.

All of our ACVs come standard with full 316 stainless steel trim for enhanced corrosion protection (unless ordered for bespoke application) and are designed and manufactured in accordance with AS5081. Mack's 33 Series is used across Water Management, Mining and Infrastructure where the demand for absolute dependability exists. It can be fitted for in excess of 20 configurations to ensure it does the job you need.

Selection & Application

The new 33 Series range comes standard in ductile iron, FBE coated, and is available in sizes from 50mm to 300mm.

This ACV can be used for a whole range of liquid mediums including potable water, seawater, aviation fuel, diesel and many others. It has been certified to AS4020 for products in contact with drinking water. Specialist application pilot systems allow the valve to be used in all applications from water level management to pump and flow control.

33 SERIES ACV DATA SHEET

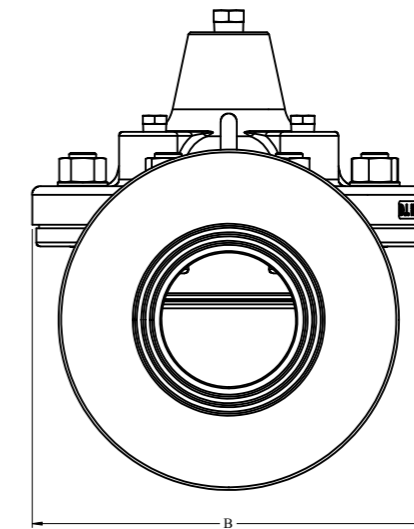

All build options are available from Mack on special order, thus enabling clients to create their own specifications for their own specific needs, but our stock is based around common material specifications favoured by the water, mining and infrastructure industries.

ITEM NO.	DESCRIPTION
1	Body
2	Cover
3	Seat
4	Cover Bearing
5	Spring
6	Stem
7	Diaphragm Washer
8	Disc Retainer
9	Disc Guide
10	Diaphragm
11	Disc
12	Spacer Washer
13	Hex Nut
14	Hex Plug
15	Hex Plug
16	Stud
17	Washer
18	Hex Nut
19	Eye Bolt

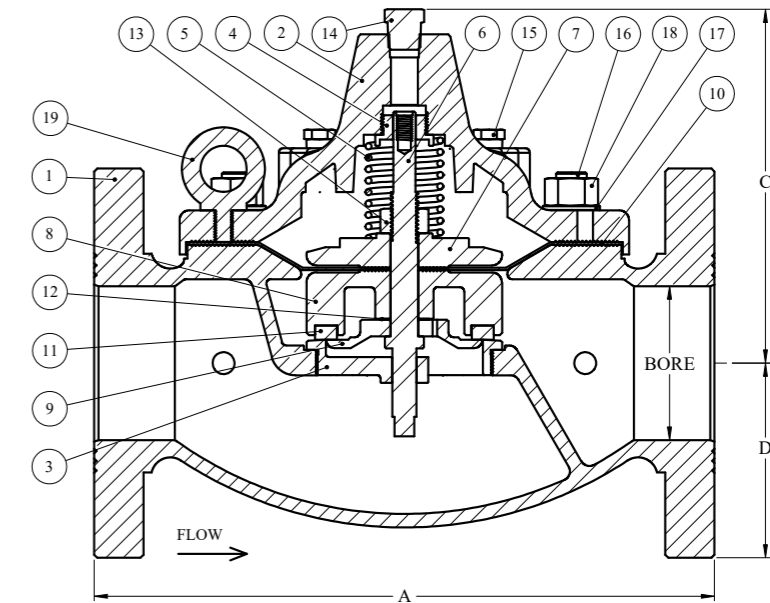

PRODUCT NUMBERING Automatic Control Valves									
33	-	#	#	#	-	##	-	###	
Base No.	-	Body Material	Trim Material	Special Feature	-	Pilot Configuration	-	Size	
33	-	6 Ductile Iron	2 BR	S Standard	-	11 Rate of Flow	-	050	
			4 SS	C Anti-Cavitation Trim	-	13 Sustaining/Relief	-	080	
				V V-Port Trim	-	18 Pressure Reducing	-	100	
				F Viton Elastomers	-	22 Main Valve Only	-	150	
				I Visual Position Ind.	-	23 Ball Float	-	200	
					-	26 Solenoid	-	250	
					-	28 Altitude	-	300	
					-	34 Twin Solenoid			

	Dimensions				Standard Port			V-Port			Anti-Cavitation Trim			Volume of Cover Chamber (L)	Weight (Kg)
	A	B	C	D	Flow Range (L/sec)	Head Loss Required (kPa)	Cv Factor	Flow Range (L/sec)	Head Loss Required (kPa)	Cv Factor	Flow Range (L/sec)	Head Loss Required (kPa)	Cv Factor		
50mm	245	168	141	83	1.5 - 14	69	1.65	0.7 - 14	108	1.32	0.25 - 14	191	0.99	0.12	17
80mm	349	230	183	105	3.0 - 30	87	3.23	1.5 - 30	135	2.59	0.5 - 30	240	1.94	0.38	35
100mm	403	292	230	127	5.0 - 52	98	5.24	2.5 - 52	153	4.19	0.8 - 52	272	3.14	0.60	63
150mm	533	405	208	159	11 - 118	92	12.28	6.0 - 118	144	9.82	2.0 - 118	255	7.37	2.00	136
200mm	671	507	380	190	20 - 204	120	18.56	10 - 204	188	14.85	3.0 - 204	334	11.14	4.20	216
250mm	791	604	451	222	30 - 321	131	28.08	16 - 321	204	22.47	5.0 - 321	363	16.85	7.60	345
300mm	914	706	551	285	45 - 460	115	42.93	25 - 460	180	34.35	7 - 460	320	25.75	12.0	579

NOTES: 1) Maximum flow is based on velocity of 6 m/s. 2) Recommended maximum velocity for continuous service is 6 m/s. 3) Recommended maximum velocity for intermittent service is 7.5 m/s. 4) Recommended maximum velocity for momentary service is 14.0 m/s. 5) Cv units are L/sec per \sqrt{kPa} . 6) All specific sizing can be calculated as per application

Our 33 Series range of ACVs have been re-engineered for today's demanding expectations.



Our valves are at the heart of industries worldwide

Around the world, our products are crucial to the safety, efficiency and reliability of companies across many critical and essential services. We have a proud reputation for quality products that have provided unquestionable reliability for decades.



Speak directly to our specialist sales team to discuss your ACV valve needs, or to get a personalised quote, call **+61 3 9737 5200**

SUPPORTING INDUSTRY SINCE 1939

Backed by 80 years of operation, Mack Valves has supported a large range of industries, offering a variety of solutions for different needs. With that experience, today Mack is focused across; Water Management, Cryogenic, General/Steam, Fire Protection, Defence and Oxygen Service Industries, with a core product range to support each one.

QUALITY AND RELIABILITY

Mack Valves is synonymous with high quality and reliability of service, and is the valve of choice when these attributes are critical. Over the years, Mack has provided flow control solutions for many hazardous applications, showing why industry chooses Mack Valves for their plant and asset protection.

FUTURE FLOW

Forward-thinking ideas drive our world, moving and changing it. By ensuring fast and innovative tailor-made solutions for our clients, Mack Valves partners with industry to deliver not just gas, steam or water, but ideas. Together we are working towards a more sustainable, efficient, and innovative world.

Learn more about our extensive range of products at mackvalves.com

EXPERT KNOWLEDGE

Our specialist sales team works with you to develop a solution right for you. If that requires a bespoke solution, we will engage our team of experienced engineers to design and manufacture a unique product for you.

PROUDLY AUSTRALIAN

Mack has been an Australian valve manufacturer and supplier to industry for over 80 years. We currently have Australian-Made Accreditation on four of our products: our 7e series, 79 series, Y and right-angled strainers.

ENGINEERED FOR INDUSTRY

Mack supplies flow control devices to Australia's critical industrial and infrastructure applications. We maintain a strong local design and engineering resource to best support Australian and Asia-Pacific industries.

MACK + HEROSE

We are a proud member of the HEROSE Group. HEROSE is one of Europe's leading manufacturers of cryogenics solutions. Mack Valves benefit from HEROSE know-how and support.



A Mack Valves quality guarantee means no down-time, enabling you to focus on driving innovation and building a whole new world of opportunities.



MACK VALVES

LETTING GOOD IDEAS FLOW