

67 SERIES

Y TYPE STRAINER

General Industry

Working Pressure from 5,000 to 10,200 Kpa

General process applications.



Relying on Mack to safeguard the integrity of your process is second nature, and extending that safeguard to include our range of strainers enhances your peace of mind.

Available in both Y Type and Angled Type configurations the large basket areas result in low pressure losses. The robust cap and body designs also result in low cost line servicing.

Our strainer can also be configured with flanged end connections, making it suitable no matter the application.

SELECTION & APPLICATION

Mack's Y & Angled type strainers are suitable for a range of applications including liquids and gases in sizes 15mm through to 300mm, in screwed BSPT and flanged. The mesh is available in various sizes and various materials for appropriate service conditions. Other special alloys are available upon request.

* For Angled type strainers contact Mack for further information.

PRODUCT NUMBERING Y Strainer

##	#	##	###
Base No.	Material of Construction	End Connection	Size
67	0 SS	8 BSPT	15
	1 Monel 400	8A NPT	20
	2 HTB1	8F Stub End	25
	4 BR	8W SW	40
	6 C1	0 Table C, D and E	50
	8 CS	1 Table F	80
		2 Table H	100
		1A #125 (CI) / #150 (OTHER)	150
		2A #250 (CI)	200
		3A #300	250
		6A #600	300

* More sizes on request

All build options are available from Mack on special order, thus enabling clients to create their own specifications for their own specific needs, but our stock is based around common material specifications favoured by the cryogenic, steam and general process industries.

Flanged Type

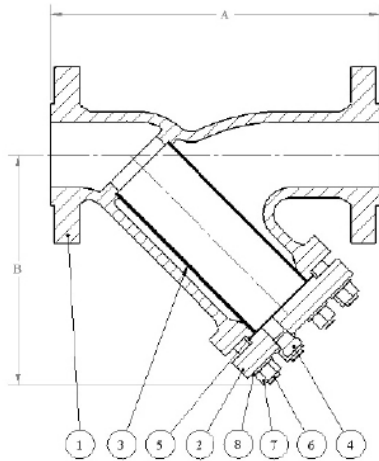

ITEM NO.	DESCRIPTION
1	Body
2	Cap
3	Screen
4	Plug
5	Gasket (optional)
6	Studs (large valves)
7	Nuts (large valves)
8	Washers (large valves)

Screwed Type

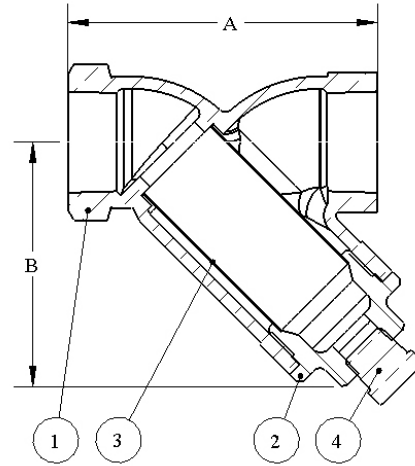

ITEM NO.	DESCRIPTION
1	Body
2	Cap
3	Screen
4	Plug

Dimensions & Properties

	Screwed		Flanged		Cv	Kv	Weight	
	A	B	A*	B			Screwed	Flanged
15mm	76	64	152	67	3.8	3.2	0.50	3.0
20mm	86	73	152	76	7.0	6.0	0.75	3.0
25mm	102	86	152	76	13	11.2	1.0	4.0
32mm	N/A	N/A	N/A	N/A	N/A	N/A	N/A	N/A
50mm	216	178	210	187	51	44	6.1	10.0
65mm	N/A	N/A	N/A	N/A	N/A	N/A	N/A	N/A
80mm	N/A	N/A	267	222	115	99	N/A	23
100mm	N/A	N/A	349	280	208	179	N/A	46
125mm	N/A	N/A	N/A	N/A	N/A	N/A	N/A	N/A
150mm	N/A	N/A	461	394	450	387	N/A	91
200mm	N/A	N/A	556	514	780	671	N/A	164
250mm	N/A	N/A	648	635	1290	1110	N/A	250
300mm	N/A	N/A	997	787	1830	1574	N/A	503

Notes

- 1) *Dimension is for flanged table H bronze product
- 2) Some material and flange types may require product with slightly different dimensions
- 3) Where for oxygen application, it is degreased, packed and labelled for Oxygen Services (ASTM G93)
- 4) *Weights for bronze valves. Other materials may have different weights.
- 5) **More sizes on request

